

# OPERATION AND MAINTENANCE MANUAL for HAND WINCH MODELS

## W2

500 lb (227 kg)

## W5

750 lb (340 kg)

## W10

1850 lb (839 kg)

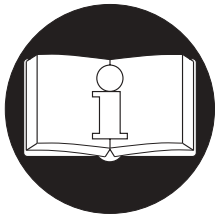
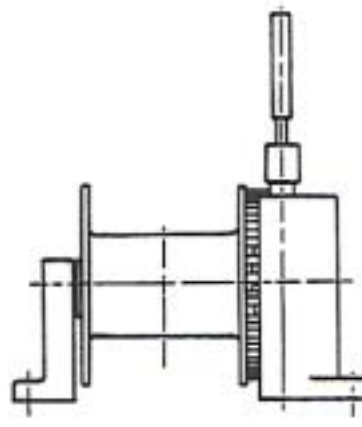
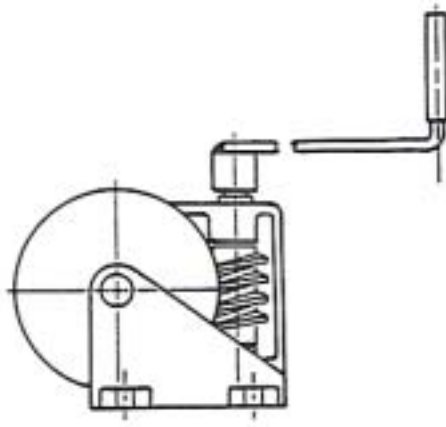

**READ THIS MANUAL BEFORE USING THESE PRODUCTS.** This manual contains important safety, installation, operation and maintenance information. Make this manual available to all persons responsible for the operation, installation and maintenance of these products.

### **⚠ WARNING**

**Do not use this winch for lifting, supporting, or transporting people or lifting or supporting loads over people.**

**Always operate, inspect and maintain this winch in accordance with American National Standards Institute Safety Code (ANSI B30.7) and any other applicable safety codes and regulations.**

**Refer all communications to WINTECH International Inc. or your nearest Distributor.**

Form MHD56002

Edition 3

November 1999

71009930

© 1999 Wintech International, L.L.C.



## SAFETY INFORMATION

This manual provides important information for all personnel involved with the safe installation, operation and proper maintenance of this product. Even if you feel you are familiar with this or similar equipment, you must read and understand this manual before operating the product.

### Danger, Warning, Caution and Notice

Throughout this manual there are steps and procedures which, if not followed, may result in a hazard. The following signal words are used to identify the level of potential hazard.

#### DANGER

Danger is used to indicate the presence of a hazard which *will* cause *severe* personal injury, death, or substantial property damage if the warning is ignored.

#### WARNING

Warning is used to indicate the presence of a hazard which *can* cause *severe* personal injury, death, or substantial property damage if the warning is ignored.

#### CAUTION

Caution is used to indicate the presence of a hazard which *will* or *can* cause *minor* personal injury or property damage if the warning is ignored.

#### NOTICE

Notice is used to notify people of installation, operation, or maintenance information which is important but not hazard-related.

### Safety Summary

#### WARNING

- **Do not use this winch for lifting, supporting, or transporting people or lifting or supporting loads over people.**
- **The supporting structures and load-attaching devices used in conjunction with this winch must provide an adequate safety factor to handle the rated load, plus the weight of the winch and attached equipment. This is the customer's responsibility. If in doubt, consult a qualified structural engineer.**

The National Safety Council, Accident Prevention Manual for Industrial Operations, Eighth Edition and other recog-

nized safety sources make a common point: Employees who work near cranes or assist in hooking on or arranging a load should be instructed to keep out from under the load. From a safety standpoint, one factor is paramount: conduct all lifting operations in such a manner that if there were an equipment failure, no personnel would be injured. This means keep out from under a raised load and keep out of the line of force of any load.

To our interpretation, **Wintech INTERNATIONAL** winches are manufactured in accordance with the latest ASME B30.7 standards.

However, contrary to common belief, the Occupational Safety and Health Act of 1970, as we understand it, generally places the burden of compliance with the user, not the manufacturer. Many OSHA requirements are not concerned or connected with the manufactured product but are, rather, connected with the final installation: "It is the owner's responsibility and user's responsibility to determine the suitability of a product for any particular use. Check all applicable industry, trade association, federal, state and local regulations. Read all operating instructions and warnings before operation."

**Rigging:** It is the responsibility of the operator to exercise caution, use common sense and be familiar with proper rigging techniques. See ANSI/ASME B30.9 for rigging information, American National Standards Institute, 1430 Broadway, New York, NY 10018.

#### NOTICE

- **Using other than genuine WINTECHINTERNATIONAL parts will result in the void of warranty.**

## SAFE OPERATING INSTRUCTIONS

The following warnings and operating instructions have been adapted in part from American National (Safety) Standard ANSI B30.7 and are intended to avoid unsafe operating practices which might lead to personal injury or property damage.

**WINTechINTERNATIONAL** recognizes that most companies who use winches have a safety program in force at their facility. In the event that some conflict exists between a rule set forth in this publication and a similar rule already set by an individual company, the more stringent of the two should take precedence.

Safe Operating Instructions are provided to make an operator aware of dangerous practices to avoid and are not necessarily limited to the following list. Refer to specific sections in the manual for additional safety information.

1. Only allow qualified personnel (trained in safety and operation) to operate and maintain a winch.
2. Only operate a winch if you are physically fit to do so.
3. When a "DO NOT OPERATE" sign is placed on the winch, do not operate the winch until the sign has been removed by designated personnel.
4. Before each shift, check the winch for wear or damage.
5. Never lift a load greater than the rated capacity of the winch. See warning labels and tags attached to winch.
6. Keep hands, clothing, etc., clear of moving parts.
7. Never place your hand in the throat area of a hook or in the vicinity of the wire rope as it spools onto the drum.
8. Always rig loads properly and carefully.
9. Be certain the load is properly seated in the saddle of the hook. Do not tiplod the hook as this leads to spreading and eventual failure of the hook.
10. Do not "side pull" or "yard".
11. Make sure everyone is clear of the load path. Do not lift a load over people.
12. Never use the winch for lifting or lowering people, and never allow anyone to stand on a suspended load.
13. Ease the slack out of the wire rope when starting a lift. Do not jerk the load.
14. Do not swing a suspended load.
15. Never suspend a load for an extended period of time.
16. Never leave a suspended load unattended.
17. Pay attention to the load at all times when operating the winch.
18. After use, properly secure winch and all loads.
19. The operator must maintain an unobstructed view of the load at all times.
20. Never use the wire rope as a sling.

## WARNING TAGS

Each winch is supplied from the factory with the warning tag shown. If the tag is not attached to your unit, order a new tag and install it. Refer to the parts list for the part number. Read and obey all warnings and other safety information attached to this winch. Tag may not be shown actual size.

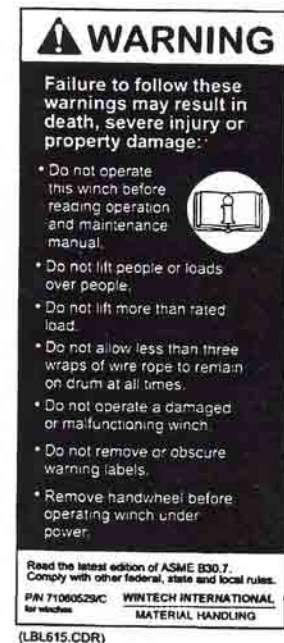

# INSTALLATION

## CAUTION

• Owners and users are advised to examine specific, local or other regulations, including American National Standards Institute and/or OSHA Regulations which may apply to a particular type of use of this product before installing or putting winch to use.

## Mounting

1. If the winch is to be mounted in one position be sure the mounting surface is even and of sufficient strength to handle the rated load and prevent possible winch damage resulting from distortion or twisting of the winch frame.
2. Make sure the winch is positioned so handle can rotate a full 360 degrees unobstructed. Reposition winch if necessary.
3. Make sure the mounting surface is flat to within 1/16 in. (2 mm). Shim if necessary.
4. Maintain a fleet angle between the sheave and winch of no more than 1-1/2 degrees. The lead sheave must be on a center line with the drum and for every inch (25 mm) of drum length, the lead sheave must be at least 1.6 feet (0.5 m) from the drum.
5. Mounting bolts for Models W2 and W5 must be 3/8 in. (M10) and for Model W10 1/2 in. (M14). All mounting bolts must be Grade 8 or better. Torque 3/8 in. (M10) bolts to 30 lb. ft. (40 N.m) and 1/2 in. (M14) bolts to 75 lb. ft. (100 N.m). Use self-locking nuts or nuts with lockwashers.

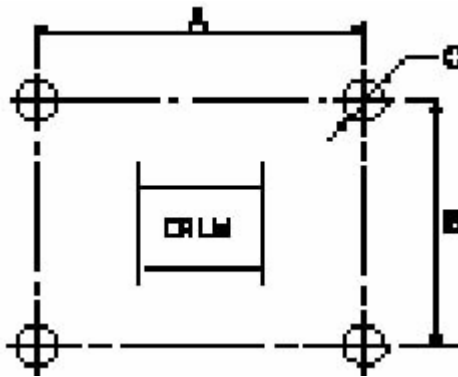

(Dwg. MHTPA0124)

## Bolt Hole Dimensions

Model No.	A		B		C	
	in.	(mm)	in.	(mm)	in.	(mm)
W2	6-3/4	171	3-7/8	98	1/2	12
W5	10-1/4	260	3-7/8	98	1/2	12
W10	13-1/2	343	5-1/4	133	5/8	16

6. Tighten mounting bolts evenly.
7. To ensure an even distribution of force, place flat washers under the fastener heads where they contact the winch frame.
8. Do not weld to any part of the winch without first receiving approval from the factory.

## Wire Rope Selection

Consult a reputable wire rope manufacturer or distributor for assistance in selecting the appropriate type and size of wire rope and, where necessary, a protective coating. Use a wire rope which provides an adequate safety factor to handle the actual working load and meets all applicable industry, trade association, federal, state and local regulations.

When considering wire rope requirements the actual working load must include not only the static or dead load but also loads resulting from acceleration, retardation and shock load. Consideration must also be given to the size of the winch wire rope drum, sheaves and method of reeving. Minimum recommended wire rope diameter is 1/8 in. (3 mm) and the maximum wire rope diameter is 5/16 in. (8 mm). The maximum diameter of the wire rope is limited by the size of the wire rope anchor.

## WARNING

• Check wire rope diameter provides adequate safety factor.

## Installing a Wire Rope

### **⚠ CAUTION**

- Position the wire rope so that it comes off the top of the drum.
- Maintain at least three full wraps of wire rope on the drum at all times.

1. Cut wire rope to length and fuse end to prevent fraying of strands in accordance with the wire rope manufacturer's instructions.

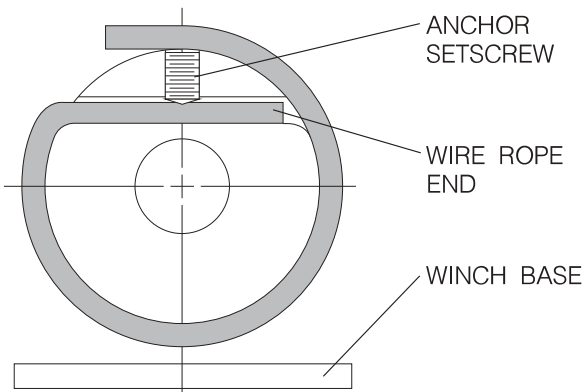

(Dwg. MHTPA0070)

2. Feed the fused end of the wire rope into the wire rope anchor hole in the drum, past the wire rope anchor setscrew, and position the end just beneath the drum surface. (See Dwg. MHTPA0070).
3. Secure by tightening wire rope anchor setscrew. Make sure wire rope anchor screw is below the surface of the drum when tightened.

## Safe Wire Rope Handling Procedures

1. Always use gloves when handling wire rope.
2. Never use wire rope which is frayed or kinked.
3. Never use wire rope as a sling.
4. Always ensure wire rope is correctly spooled and first layer is tight.

### Wire Rope Spooling

To allow for uneven spooling and decrease in line pull capacity as the drum fills up, use as short a wire rope as practical. Always maintain three or more wraps of wire rope on the drum. When rewinding wire rope apply tension to eliminate slack. This helps achieve level winding, tight spooling and avoids "Birdnesting".

### Rigging

Make sure all wire rope blocks, tackle and fasteners have sufficient safety margin to handle the required load. Do not allow wire rope to contact sharp edges or make sharp bends which will cause damage to wire rope. Use a sheave. Refer to wire rope manufacturer's handbook for proper sizing, use and care of wire rope.

### Safe Installation Procedures

1. Do not use wire rope as a ground (earth) for welding.
2. Do not attach a welding electrode to winch or wire rope.
3. Never run the wire rope over a sharp edge. Use a correctly sized sheave.
4. When a lead sheave is used, it must be aligned with the center of the drum. The diameter of the lead sheave must be at least 18 times the diameter of the wire rope.
5. Always maintain at least three full wraps of wire rope on the drum.

## OPERATION

The four most important aspects of winch operation are:

1. Follow all safety instructions when operating the winch.
2. Allow only qualified people to operate the winch.
3. Subject each winch to a regular inspection and maintenance procedure.
4. Be aware of the winch capacity and weight of load at all times.

### **⚠ WARNING**

- WINTECH INTERNATIONAL products are not designed or suitable for lifting, lowering or moving persons. Never lift loads over people.
- Do not use power to drive the winch.
- Maintain at least three full wraps of wire rope on the drum at all times.

### Handle Attachment

Align groove in handle (5) with roll pin (9B) in worm shaft (7). Press handle (5) down until roll pin (9B) is seated at root of handle groove. Insert cotter pin (12) through hole in handle (5) and worm shaft (7). If inserting the cotter pin (12) is difficult, make sure handle (5) has been completely pressed onto the worm shaft (7). Secure by bending ends of cotter pin (12) apart.

### **⚠ WARNING**

- A creeping load can cause death or injury. Do not rely on the worm gear reduction to hold a suspended load.
- Do not overload winch.

## Paying Out or Hauling In

When facing the large frame (1) side of the winch:

Rotate the handle (5) clockwise to rotate the drum clockwise.

Rotate the handle (5) counterclockwise to rotate the drum counterclockwise.

To avoid “bird nesting” caused by slack wire rope, apply tension to the wire rope when spooling onto the drum.

## ⚠ WARNING

• When the handle stops moving the worm gear reduction causes the drum to stop, giving the impression of a self-locking mechanism. However, to provide adequate safety, a separate locking device must be used to secure the load.

## INSPECTION

There are two types of inspection, the frequent inspection performed by the operator while using the winch and more thorough periodic inspections performed by qualified personnel. Careful inspection on a regular basis will reveal potentially dangerous conditions while still in the early stages, allowing corrective action to be taken before the condition becomes dangerous.

Any deficiency revealed through inspection must be reported to an appointed person. A determination must be made as to whether a deficiency constitutes a safety hazard before resuming operation of the winch.

### Frequent Inspection

On winches in continuous service, frequent inspection should be made at the beginning of each shift. In addition, visual observations should be conducted during regular service for any damage or evidence of malfunction.

1. OPERATION. To make sure the drive mechanism operates properly, check for sticking or other signs of malfunction. Repair if necessary.
2. LIMIT DEVICES. If used, check that they operate properly.
3. WIRE ROPE. Lubricate if necessary. Replace the wire rope if damaged or excessively worn. Consult the wire rope manufacturer’s inspection information or a recognized safety source, such as the latest edition of National Safety Council, Accident Prevention Manual for Industrial Operations or ANSI/ASME B30.7. The following list is a users guide to the accepted standards by which wire rope must be judged and is not presented as a substitute for an experienced inspector.
  - a. Damage, such as: bird cages, kinking, core protrusion, crushing and main strand displacement.
  - b. Corrosion, nicking and wear of crown wires.
  - c. Wear of crown wires. Replace at 1/3 wear of the original diameter of any crown wire.
  - d. Broken wires or strands, particularly at connections. Replacement is necessary if one wire is broken at a connection; six wires broken within one lay; three wires broken in one strand within one lay.
4. WIRE ROPE REEVING. Check reeving and ensure

wire rope is properly secured to the drum.

5. LUBRICATION. See "LUBRICATION" section for recommended procedures.

### Periodic Inspection

According to ANSI/ASME B30.7, frequency of periodic inspection depends on the severity of usage: **NORMAL**, yearly; **HEAVY**, semi-annually; **SEVERE**, quarterly. Disassembly may be required for **HEAVY** or **SEVERE** usage. Keep accumulative records of periodic inspections to provide a basis for continuing evaluation.

Inspect all items in “Frequent Inspection” also inspect the following:

1. MEMBERS. Check for deformed, cracked or corroded main components. Replace damaged parts if necessary.
2. FASTENERS. Check rivets, cotter pins, capscrews and nuts on winch, including mounting bolts. Replace if missing or tighten if loose.
3. DRUM. Check for cracks, damage or excessive wear. Replace if necessary.
4. ALL COMPONENTS. Inspect for wear, damage, distortion and cleanliness. If external evidence indicates the need, for example poor performance or excessive noise, disassemble and inspect. Check pins, gears, shafts, bearings, sheaves, covers, etc. Replace worn or damaged parts.
5. SUPPORTING STRUCTURE. Check for distortion, wear and continued ability to support the winch and load.
6. LABELS AND TAGS. Check for presence and legibility. Replace if necessary.
7. WIRE ROPE. Besides the items in a frequent inspection, inspect the following:
  - a. Build-up of dirt and corrosion. Clean if necessary.
  - b. Loose or damaged end connection. Replace if loose or damaged.
  - c. Check wire rope anchor is secure.
  - d. Changes in the size of the wire rope diameter.

Periodically measure the diameter of the wire rope from crown-to-crown throughout the life of the wire rope. The actual diameter should be recorded when the wire rope is under equivalent loading and in the same operating section. If the actual diameter of the wire rope has decreased more than 1/64 in. (0.4 mm) a through examination of the wire rope should be conducted by an experienced inspector to determine the suitability of the wire rope to remain in service. (see Dwg. MHTPA0056).

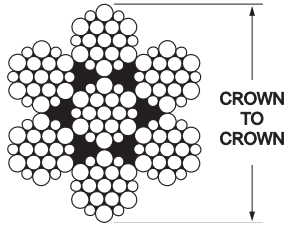

(Dwg. MHTPA0056)

**⚠ WARNING**

- **Never use a winch that inspection indicates is defective.**

**Winches Not in Regular Use**

A winch which has been idle for a period of one month or more, but less than six months, shall be given an inspection conforming with the requirements of "Frequent Inspection" before being placed into service.

A winch which has been idle for a period of over six months shall be given a complete inspection conforming with the requirements of "Periodic Inspection".

Standby winches shall be inspected at least semi-annually in accordance with the requirements of "Frequent Inspection". If abnormal operating conditions apply winches may require a more frequent inspection.

**Testing**

**Operational Tests**

Prior to initial use, all new, altered or repaired winches shall be tested to ensure proper operation.

- Operate winch in both directions with no load.
- Check operation of limit switches, and locking or safety devices when provided.
- Check all tie-downs are secure.
- Check all covers and guards are installed.

**Rated Load Test**

Prior to initial use, all new, extensively repaired, or altered winches shall be tested by or under the direction of a qualified person, and a written report furnished confirming the rating of the winch. Test loads shall not be more than 110% of the rated line pull.

**LUBRICATION**

**⚠ CAUTION**

- **Lubricate the winch regularly using only the recommended grease.**

**Gears**

Lubricate teeth of worm (4A) and drum (3). Brush with grease as often as necessary to keep teeth liberally covered with grease. If the grease becomes contaminated with sand, dirt or other abrasive materials, clean off old grease and brush on new. For temperatures -20° to 50° F (-29° to 10° C) use a multipurpose lithium-based EP 1 grease. For temperatures 30° to 120° F (-1° to 49° C) use a multipurpose lithium-based EP 2 grease.

**Grease Fittings**

Lubricate all grease fittings (8) quarterly, or more frequently, depending on severity of service. See assembly drawing for location of fittings (8). To access the grease fitting (8) on the inboard end of the drum, rotate the handle (5) until the grease fitting (8) is exposed. For temperatures -20° to 50° F (-29° to 10° C) use water-resistant EP 1 grease or equivalent. For temperatures 30°

to 120° F (-1° to 49° C) use water-resistant EP 2 grease or equivalent.

**Wire Rope**

Follow the wire rope manufacturer's instructions. At a minimum, observe the following guidelines.

**⚠ CAUTION**

- **Do not use an acid-based solvent. Only use cleaning fluids specified by the wire rope manufacturer.**

- If there is dirt, rock dust or other foreign material on the surface of the rope, clean with a brush or steam.
- Apply a wire rope lubricant or SAE 30 W oil.
- Brush, drip or spray lubricant weekly, or more frequently, depending on severity of service.

## ⚠ WARNING

- Never perform maintenance on the winch while it is supporting a load.
- Before performing maintenance, tag winch: **DANGER - DONOT OPERATE - EQUIPMENT BEING REPAIRED.**
- Only allow qualified service personnel to perform maintenance.
- After performing any maintenance on the winch, test winch to 110% of its rated capacity before returning to service.

Make sure that all parts are in place and operating correctly. Replace worn or missing parts with genuine WINTECHINTERNATIONAL factory replacement parts.

### General Disassembly

The following instructions provide the necessary information to disassemble, inspect, repair, and assemble the winch. An exploded drawing of the winch is provided in the Parts Section to assist part identification.

It is recommended that all maintenance work on the winch be performed on a sturdy work bench.

In the process of disassembling the winch, observe the following:

1. Never disassemble the winch any further than is necessary to accomplish the needed repair. A good part can be damaged during the course of disassembly.
2. Never use excessive force when removing parts. Tapping gently around the perimeter of a part with a soft hammer should be sufficient to loosen the part.
3. Do not heat a part with a flame to free it for removal, unless the part being heated is already worn or damaged beyond repair and no additional damage will occur to other parts.

In general, the winch is designed to permit easy disassembly and assembly. The use of heat or excessive force should not be required.

4. When grasping a part in a vise, always use leather-covered or copper-covered vise jaws to protect the surface of the part and help prevent distortion. This is particularly true of threaded members and shafts.
5. Do not remove any part which is press fit in or on a subassembly unless the removal of that part is necessary for repairs or replacement.

### Winch Disassembly

1. Remove the wire rope from the winch. Remove winch from its mounting and take to a suitable work area.
2. Remove handle (5) and gear cover (14) if used.
3. Drive roll pin (9A) out of small frame (2). Use a tapered starter punch to loosen the pin, then use a long, thin punch to drive through roll pin (9A).

4. Remove small frame (2). Slide drum (3) off drum shaft (6).
5. If the drum shaft (6) needs to be removed, drive out roll pin (9A) which secures drum shaft (6) to large frame (1). Carefully remove drum shaft (6) by tapping it out with a hammer and note which end was installed in large frame (1).
6. Rotate the worm assembly (4) until there is enough clearance between the large frame (1) and the worm (4A) to remove roll pin (9B). Drive out roll pin (9B) which secures worm shaft (7) to worm (4A).
7. Remove worm shaft (7) out of the top of large frame (1). The top of the large frame (1) is the side where the handle (5) is attached. Remove worm (4A).
8. For each worm bushing (10) to be removed, remove its grease fitting (8). Place the claws of a hammer under the head of the fitting (8) and pry up.
9. Press out, or carefully drive out, bushings (10).

### Cleaning, Inspection and Repair

Use the following procedures to clean, inspect, and repair the components of the winch.

#### Cleaning

Clean all winch component parts in solvent. The use of a stiff bristle brush will facilitate the removal of accumulated dirt and sediments on the gears, frames and drum. Dry each part using low pressure, filtered compressed air.

#### Inspection

All disassembled parts should be inspected to determine their fitness for continued use. Pay particular attention to the following:

1. Inspect all gears for worn, cracked, or broken teeth.
2. Inspect shafts for ridges caused by wear. If ridges caused by wear are apparent on shafts, replace the shaft.
3. Inspect all threaded items and replace those having damaged threads.
4. Inspect bushings (10) for wear, scoring or galling. Model W2 and W5 original bushing bore diameter is .814 in. (20.7 mm) replace bushing if bore diameter exceeds .870 in. (22 mm). Model W10 original bushing bore diameter is .752 in. (19.1 mm) replace bushing if bore diameter exceeds .810 in. (21 mm).

#### Repair

Actual repairs are limited to the removal of small burrs and other minor surface imperfections from gears and shafts. Use a fine stone or emery cloth for this work.

1. Worn or damaged parts must be replaced. Refer to the



applicable Parts Listing for specific replacement parts information.

2. Inspect all remaining parts for evidence of damage. Replace or repair any part which is in questionable condition. The cost of the part is often minor in comparison with the cost of redoing the job.
3. Smooth out all nicks, burrs, or galled spots on shafts and in bores.
4. Examine all gear teeth carefully, and remove nicks or burrs.
5. Polish the edges of all shaft shoulders to remove small nicks which may have been caused during handling.
6. Remove all nicks and burrs caused by lockwashers.

## Winch Assembly

### NOTICE

• **Always replace roll pins (9A and 9B) if they have been removed.**

1. Install worm bushings (10) making sure they go in evenly and are fully seated.
  - a. To reinstall an old bushing (10). Align the grease fitting holes in the large frame (1) and bushing (10). Tap lightly with a hammer or press the bushing (10) into the large frame (1). Check grease fitting hole has remained aligned.
  - b. To install a new bushing (10). Tap lightly with a hammer or press bushing (10) into the large frame (1). Drill a hole in the bushing, through the grease fitting hole in the large frame (1). Use a #14 drill bit.

### NOTICE

• **Pounding on the top of the grease fitting (8) will cause damage.**

2. Install grease fittings (8). Use a socket large enough to fit over the nipple, but small enough to press on the base of the fitting (8). Tap lightly.
3. If a new worm assembly (4) is being installed, disassemble the matched set of worm (4A) and worm shaft (7) by driving out roll pin (9B). Position worm (4A) in the large frame (1) with the roll pin hole at the bottom. Insert worm shaft (7) through top of large frame (1).
4. Align holes in worm shaft (7) and worm (4A) and secure by installing roll pin (9B). On new worm assemblies (4), install a second roll pin (9B) for handle attachment.
5. Insert the end of drum shaft (6) having the longer distance between the end of the shaft and the roll pin hole into the large frame (1). Align the roll pin holes and secure by installing roll pin (9A).
6. Pack the interior of drum (3) with grease. Slide "toothed" end of drum (3) over drum shaft (6). If necessary, rotate the worm (4) or drum (3) to mate the teeth.
7. Align holes through small frame (2) and drum shaft (6). Secure by installing roll pin (9A).

### NOTICE

• **If operation of the winch is difficult, the worm bushings (10) may be misaligned. To align bushings (10), tap gently with a rubber mallet on both ends of the worm assembly (4).**

#### Test Check

Upon completion of all winch maintenance and repairs check winch operation following procedures in the "INSTALLATION" section.

## PARTS ORDERING INFORMATION

The use of replacement parts other than **WINTECHINTERNATIONAL** will invalidate the Company's warranty. For prompt service and genuine **WINTECHINTERNATIONAL** parts, provide your nearest Distributor with the following:

1. Complete model number: W2, W5, and W10.
2. Part number and part description as shown in this manual.
3. Quantity required.

#### Return Goods Policy

**WINTECHINTERNATIONAL** will not accept any returned goods for warranty or service unless prior arrangements have been made and written authorization has been provided from the location the goods were purchased.

### NOTICE

• **Continuing improvement and advancement of design may cause changes to this winch which are not included in this manual. Manuals are periodically revised to incorporate changes. Always check the manual edition number on the front cover for the latest issue.**

# W SERIES WINCH ASSEMBLY DRAWING AND PARTS LIST

ITEM NO.	DESCRIPTION OF PART	TOTAL QTY.	PART NO.			
			W2	W5	W7**	W10
1	Large Frame	1	1329		1327	
2	Small Frame	1	1330		1328	
3	Drum	1	Not Sold Separately		Not Sold Separately	
4	Worm Assembly (Incl's items 4A, 7 and 9A)	1	397-A		377-A	
4A	Worm	1	Order item no. 4		Order item no. 4	
5	Handle (Incl's 12 items)	1	863-1		863-2	
6	Drum Shaft	1	B229	396	381	382
7	Worm Shaft	1	Order item no. 4		Order item no. 4	
•8	Grease Fitting	see ()	53477 (3)		53477 (4)	
9A	Roll Pin	2	71001135		71001143	
•9B	Roll Pin	2	71001135		52332	
•10	Worm Bushing	2	1334-1		1334-2	
11	Wire Rope Anchor	1	51088		50980	
12	Cotter Pin	1	54165			
13	Warning Tag	1	71056410			
14*	Gear Cover	1	6191		6192	
15*	Screw	4	71007009			
16	Rivet	1	50915			

\* Optional

" Model discontinued Jan 1991

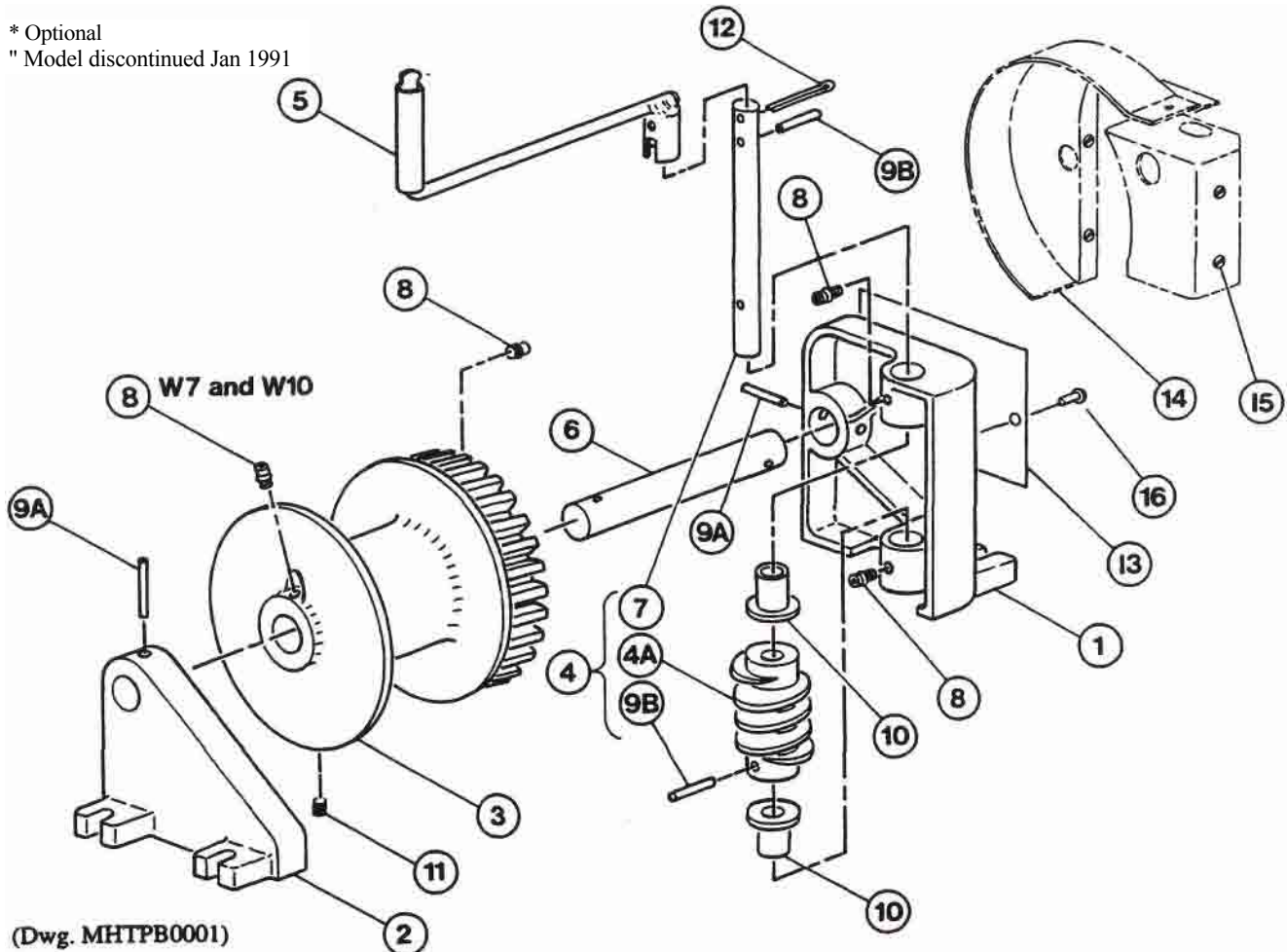

I Recommended Spare

Touch-Up Paint Part No. MHD-OR

## HOIST AND WINCH LIMITED WARRANTY

WINTECH INTERNATIONAL warrants to the original user its Hoists and Winches (Products) to be free of defects in material and workmanship for a period of one year from the date of purchase. WINTECH will repair, without cost, any Product found to be defective, including parts and labor charges, or at its option, will replace such Products or refund the purchase price less a reasonable allowance for depreciation, in exchange for the Product. Repairs or replacements are warranted for the remainder of the original warranty period.

If any Product proves defective within its original one year warranty period, it should be returned to any Authorized Hoist and Winch Service Distributor, transportation prepaid with proof of purchase or warranty card.

This warranty does not apply to Products which WINTECH has determined to have been misused or abused, improperly maintained by the user, or where the malfunction or defect can be attributed to the use of non-genuine WINTECH parts.

**WINTECH makes no other warranty, and all implied warranties including any warranty of merchantability or fitness for a particular purpose are limited to the duration of the expressed warranty period as set forth above. WINTECH's maximum liability is limited to the purchase price of the Product and in no event shall WINTECH be liable for any consequential, indirect, incidental, or special damages of any nature rising from the sale or use of the Product, whether based on contract, tort, or otherwise.**

**Note:** Some states do not allow limitations on incidental or consequential damages or how long an implied warranty lasts so that the above limitations may not apply to you.

This warranty gives you specific legal rights and you may also have other rights which may vary from state to state.

## IMPORTANT NOTICE

It is our policy to promote safe delivery of all orders.

This shipment has been thoroughly checked, packed and inspected before leaving our plant and receipt for it in good condition has been received from the carrier. Any loss or damage which occurs to this shipment while enroute is not due to any action or conduct of the manufacturer.

### **VISIBLE LOSS OR DAMAGE**

If any of the goods called for on the bill of lading or express receipt are damaged or the quantity is short, do not accept them until the freight or express agent makes an appropriate notation on your freight bill or express receipt.

### **CONCEALED LOSS OR DAMAGE**

When a shipment has been delivered to you in apparent good condition, but upon opening the

crate or container, loss or damage has taken place while in transit, notify the carrier's agent immediately.

### **DAMAGE CLAIMS**

You must file claims for damage with the carrier. It is the transportation company's responsibility to reimburse you for repair or replacement of goods damaged in shipment. Claims for loss or damage in shipment must not be deducted from the WINTECH INTERNATIONAL invoice, nor should payment of WINTECH INTERNATIONAL invoice be withheld awaiting adjustment of such claims as the carrier guarantees safe delivery.

You may return products damaged in shipment to us for repair, which services will be for your account and form your basis for claim against the carrier.

## **United States Office Location**

**For Order Entry, Order Status, and  
Technical Support:**

**Wintech International, L.L.C.  
5319 Shreveport/Blanchard Hwy.  
Shreveport, LA. 71107**

**Phone: (318) 929-1242  
1-888-946-8325  
Fax: (318) 929-1245  
[www.wintech-winch.com](http://www.wintech-winch.com)**

